

Autonics ROTARY ENCODER (INCREMENTAL TYPE) E50S SERIES INSTRUCTION MANUAL



Thank you for choosing our Autonics product.
Please read the following safety considerations before use.

■ Safety Considerations

⚠ Please observe all safety considerations for safe and proper product operation to avoid hazards.

⚠ symbol represents caution due to special circumstances in which hazards may occur.

Warning Failure to follow these instructions may result in serious injury or death.

Caution Failure to follow these instructions may result in personal injury or product damage.

⚠ Warning

1. **Fail-safe device must be installed when using the unit with machinery that may cause serious injury or substantial economic loss.** (e.g. nuclear power control, medical equipment, ships, vehicles, railways, aircraft, combustion apparatus, safety equipment, crane/disaster prevention devices, etc.)
Failure to follow this instruction may result in fire, personal injury, or economic loss.

2. **Install on a device panel to use.**

Failure to follow this instruction may result in fire.

3. **Do not connect, repair, or inspect the unit while connected to a power source.**

Failure to follow this instruction may result in fire.

4. **Check 'Connections' before wiring.**

Failure to follow this instruction may result in fire.

5. **Do not disassemble or modify the unit.**

Failure to follow this instruction may result in fire.

⚠ Caution

1. **Use the unit within the rated specifications.**

Failure to follow this instruction may result in fire or product damage.

2. **Do not short the load.**

Failure to follow this instruction may result in product damage by fire.

3. **Do not use the unit in the place where flammable/explosive/corrosive gas, humidity, direct sunlight, radiant heat, vibration, impact, or salinity may be present.**

Failure to follow this instruction may result in fire or explosion.

4. **Do not use the unit near the place where there is the equipment which generates strong magnetic force or high frequency noise and strong alkaline, strong acidic exists.**

Failure to follow this instruction may result in product damage.

■ Ordering Information

E50S	8	8000	3	N	24	
Series	Shaft diameter	Pulse/1Revolution	Output phase	Control output	Power supply	Cable
Ø50mm, shaft type	Ø8mm	Refer to resolution	2: A, B 3: A, B, Z 4: A, \bar{A} , B, \bar{B} 6: A, \bar{A} , B, \bar{B} , Z, Z	T: Totem pole output N: NPN open collector output V: Voltage output L: Line driver output	5: 5VDC±5% 24: 12-24VDC ±5%	No mark: Axial cable type C: Axial cable connector type (×) CR: Axial connector type CS: Radial connector type

※Standard: E50S8-PULSE-3-N-24 ※Cable length: 250mm

■ Control Output Diagram

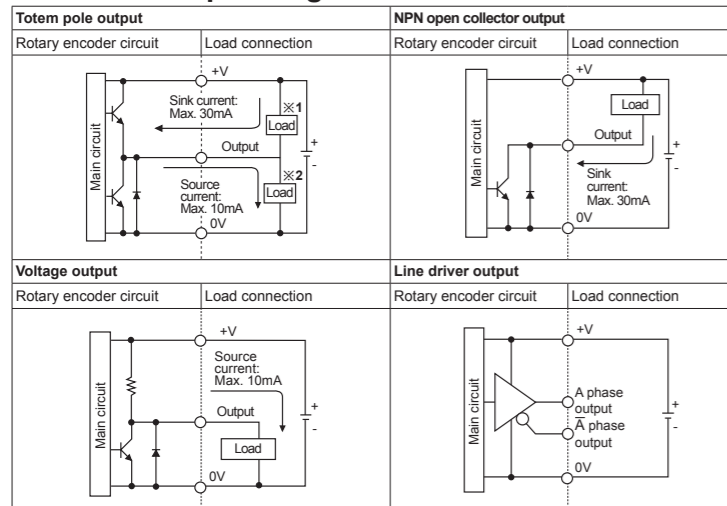

※All output circuits of A, B, Z phase are the same. (line driver output is A, \bar{A} , B, \bar{B} , Z, Z)
 ※Totem pole output type can be used for NPN open collector type (×1) or voltage output type (×2).
 ※The above specifications are subject to change and some models may be discontinued without notice.
 ※Be sure to follow cautions written in the instruction manual, and the technical descriptions (catalog, homepage).

■ Specifications

Item	Diameter Ø50mm shaft type of incremental rotary encoder			
Model	Totem pole output	E50S8-□-3-T-□-□		
	NPN open collector output	E50S8-□-3-N-□-□		
	Voltage output	E50S8-□-3-V-□-□		
	Line driver output	E50S8-□-6-L-□-□		
Resolution (PPR) ^{※1}	*1, *2, *5, 10, 12, 15, 20, 23, 25, 30, 35, 40, 45, 50, 60, 75, 100, 120, 125, 150, 192, 200, 240, 250, 256, 300, 360, 400, 500, 512, 600, 800, 1000, 1024, 1200, 1500, 1800, 2000, 2048, 2500, 3000, 3600, 4000, 5000, 6000, 8000			
Output phase	A, B, Z phase (line driver output: A, \bar{A} , B, \bar{B} , Z, Z phase)			
Phase difference of output	Output between A and B phase: $\frac{T}{4} \pm \frac{T}{8}$ (T=1 cycle of A phase)			
Electrical specification	Control output	Totem pole output	• [Low] - Load current: Max. 30mA, Residual voltage: MAax. 0.4VDC= • [High] - Load current: Max. 10mA, Output voltage (power voltage 5VDC=): Min. (power voltage-2.0)VDC=, Output voltage (power voltage 12-24VDC=): Min. (power voltage-3.0)VDC=	
		NPN open collector output	Load current: Max. 30mA, Residual voltage: Max. 0.4VDC=	
		Voltage output	Load current: Max. 10mA, Residual voltage: Max. 0.4VDC=	
		Line driver output	• [Low] - Load current: Max. 20mA, Residual voltage: Max. 0.5VDC= • [High] - Load current: Max. -20mA, Output voltage (power voltage 5VDC=): Min. 2.5VDC=, Output voltage (power voltage 12-24VDC=): Min. (power voltage-3.0)VDC=	
Response time (rise/fall)	Line driver output	Totem pole output	Max. 1µs (cable length: 2m, I sink=20mA)	
		NPN open collector output	Max. 1µs (cable length: 2m, I sink=20mA)	
		Voltage output	Max. 0.5µs (cable length: 2m, I sink=20mA)	
		Line driver output	Max. 0.5µs (cable length: 2m, I sink=20mA)	
Mechanical specification	Max. response frequency	300kHz		
	Power supply	• 5VDC= ±5% (ripple P-P: Max. 5%) • 12-24VDC= ±5% (ripple P-P: Max. 5%)		
	Current consumption	Max. 80mA (disconnection of the load), Line driver output: Max. 50mA (disconnection of the load)		
	Insulation resistance	Over. 100MΩ (at 500VDC megger between all terminals and case)		
	Dielectric strength	750VAC 50/60Hz for 1 minute (between all terminals and case)		
	Connection	Axial cable type, Axial cable connector type, Axial/Radial connector type		
	Starting torque	Max. 70gf·cm (0.007N·m) ^{※2} , Max. 800gf·cm (0.078N·m) ^{※3}		
	Moment of inertia	Max. 80g·cm ² (8×10 ⁻⁶ kg·m ²) ^{※2} , Max. 400g·cm ² (4×10 ⁻⁶ kg·m ²) ^{※3}		
	Shaft loading	Radial: Max. 10kgf, Thrust: Max. 2.5kgf		
	Max. allowable revolution ^{※4}	5,000rpm		
	Vibration	1.5mm amplitude at frequency of 10 to 55Hz in each X, Y, Z direction for 2 hours		
	Shock	Approx. Max. 75G		
	Environment	Ambient temperature	-10 to 70°C, Storage: -25 to 85°C	
		Ambient humidity	35 to 85% RH, Storage: 35 to 90%RH	
Protection structure	Axial cable type, Axial cable connector type: P50 (IEC standards) ^{※5} , Axial/Radial connector type: P65 (IEC standards)			
Cable	Ø5mm, 5-wire, Length: 2m, Shield cable (line driver output: Ø5mm, 8-wire) (AWG 24, Core diameter: 0.08mm, Number of cores: 40, Insulator diameter: Ø1mm)			
Accessory	Ø8mm coupling, Bracket			
Approval	CE (except line driver output)			
Weight ^{※6}	Approx. 363g (approx. 275g), Axial/Radial connector type: Approx. 268g (approx. 180g)			

※1 "*" pulse is only for A, B phase. (but Line driver output: A, \bar{A} , B, \bar{B} phase) Not indicated resolutions are customizable.
 ※2 This value is for Axial cable type, Axial cable connector type (protection structure: P50).
 ※3 This value is for Axial cable type, Axial cable connector type (protection structure: P64), Axial/Radial connector type (protection structure: P65).
 ※4 Make sure that Max. response revolution should be lower than or equal to max. allowable revolution when selecting the resolution.
 [Max. response revolution (rpm) = $\frac{\text{Resolution}}{\text{Resolution}} \times 60 \text{ sec}$]
 ※5 In case of axial cable type, axial cable connector type, they are available to order the option protection structure IP64.
 ※6 The weight includes packaging. The weight in parentheses is for unit only.
 ※Environment resistance is rated at no freezing or condensation.

■ Dimensions

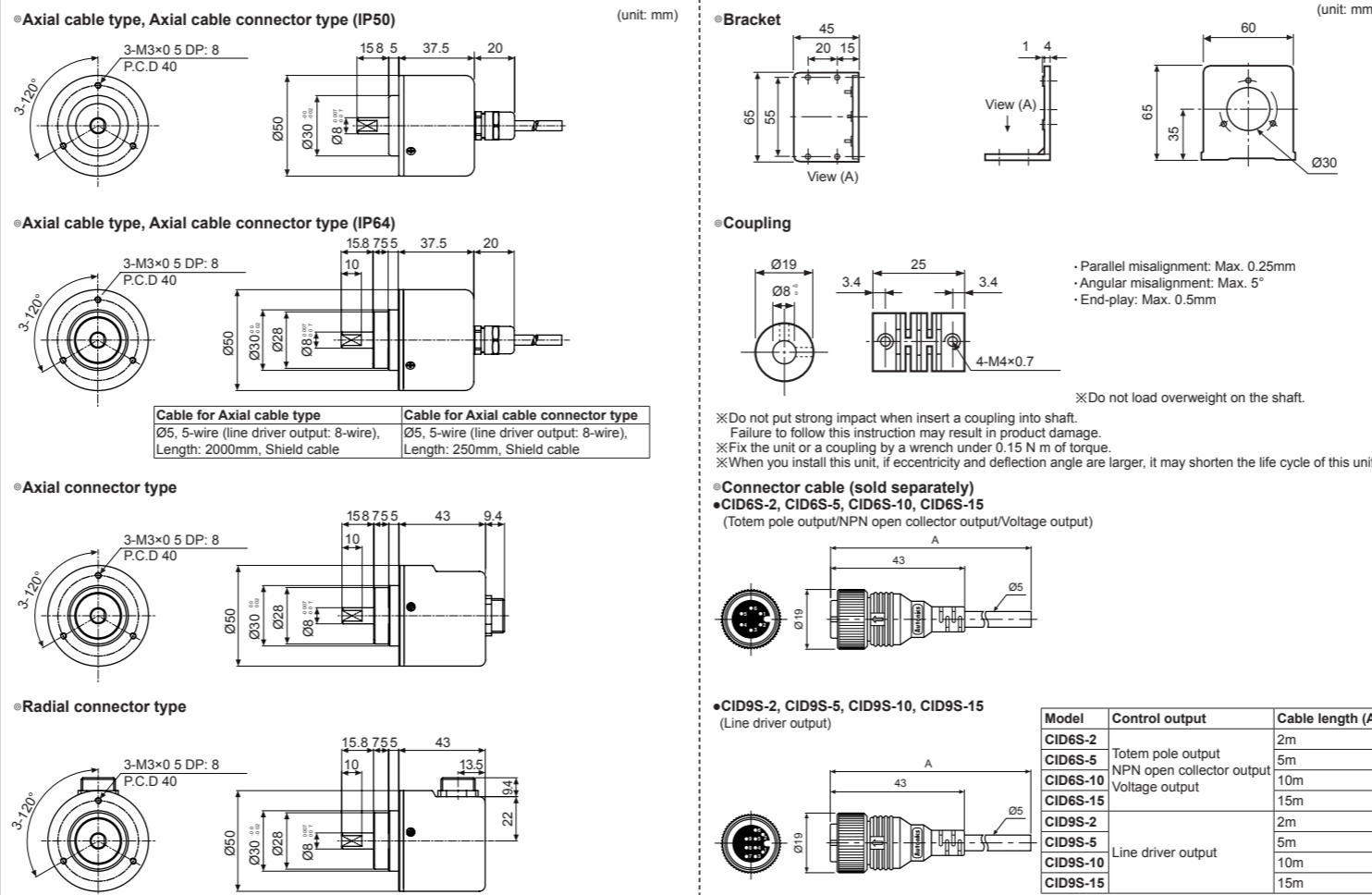

■ Connections

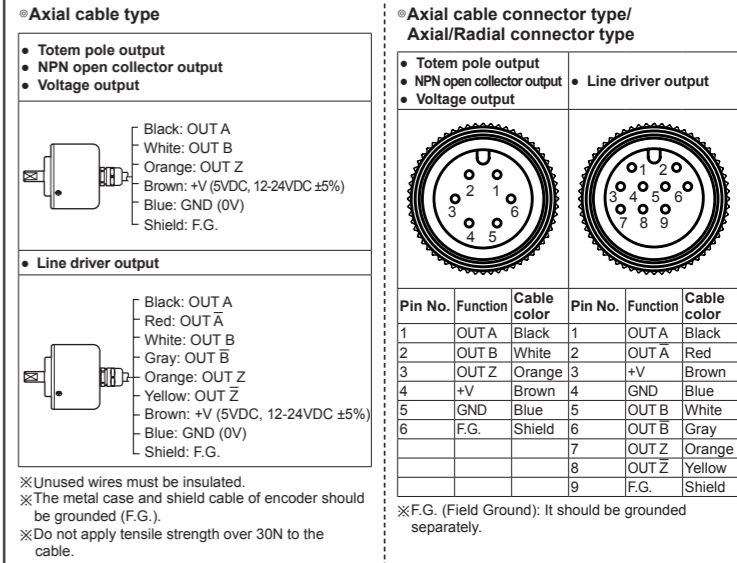

■ Output Waveforms

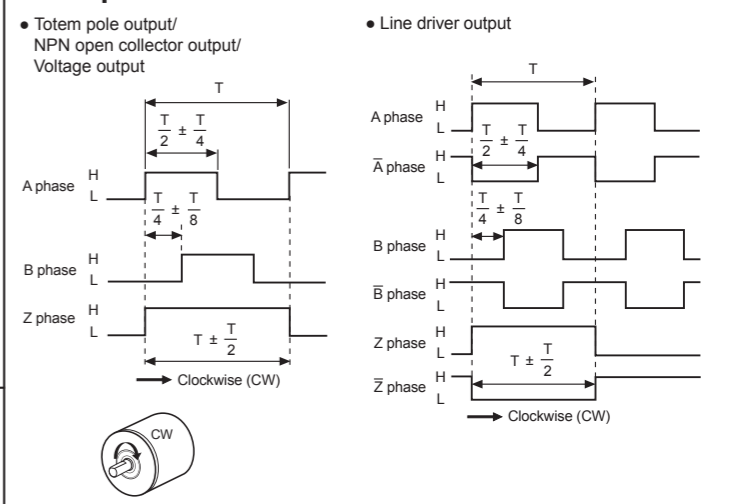

■ Cautions during Use

- Follow instructions in 'Cautions during Use'. Otherwise, it may cause unexpected accidents.
- 5VDC, 12-24VDC power supply should be insulated and limited voltage/current or Class 2, SELV power supply device.
- For using the unit with the equipment which generates noise (switching regulator, inverter, servo motor, etc.), ground the shield wire to the F.G. terminal.
- Ground the shield wire to the F.G. terminal.
- When using switching mode power supply, frame ground (F.G.) terminal of power supply should be grounded.
- Wire as short as possible and keep away from high voltage lines or power lines, to prevent inductive noise.
- For Line driver unit, use the twisted pair wire which is attached seal and use the receiver for RS-422A communication.
- Check the wire type and response frequency when extending wire because of distortion of waveform or residual voltage increment etc by line resistance or capacity between lines.
- This unit may be used in the following environments.
 - ①Indoors (in the environment condition rated in 'Specifications')
 - ②Altitude max. 2,000m
 - ③Pollution degree 2
 - ④Installation category II

■ Major Products

- Photoelectric Sensors
- Fiber Optic Sensors
- Door Sensors
- Door Side Sensors
- Area Sensors
- Proximity Sensors
- Pressure Sensors
- Rotary Encoders
- Connector/Sockets
- Switching Mode Power Supplies
- Control Switches/Lamps/Buzzers
- I/O Terminal Blocks & Cables
- Stepper Motors/Drivers/Motion Controllers
- Graphic/Logic Panels
- Field Network Devices
- Laser Marking System (Fiber, CO₂, Nd: YAG)
- Laser Welding/Cutting System
- Temperature Controllers
- Temperature/Humidity Transducers
- SSRs/Power Controllers
- Counters
- Timers
- Panel Meters
- Tachometer/Pulse (Rate) Meters
- Display Units
- Sensor Controllers